

CAS-1250-2T-15HP

ACCESSORIES
AERATION
SYSTEM



FILE 5.45
VERSION 2. 17/07/2021

COD. 30CAS12502

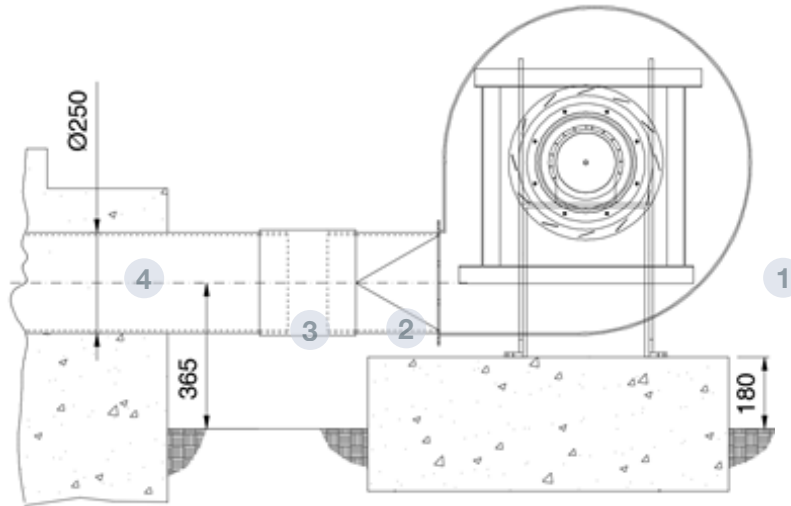

DESCRIPTION

Medium pressure centrifugal fan and single aspiration, big strength, equipped with a turbine.

Anticorrosive finishing process with polymeric polyester resins (190 °C).

Previously, degreasing nanotechnologist treatment free of phosphates.

Placed at the base of the silo, outside, either connected to the aeration channels, a ventilated cone or a full perforated floor. When the aeration is for a hopper silo, the fan is directly screwed to a hopper sector prepared for it.

TECHNICAL SPECIFICATIONS		MOTOR DATA SHEET	
Flow rate (m ³ /h)	9274	Nominal Power (kW)	11
Speed (rpm)	2951	Max flow (m ³ /h)	12000
Performance	69	Hz/phses	50/3
Efficiency grade N	69	Motor (rpm)	2945
Measurements category	B	Max. Current (A) 230 V	20
Efficiency category	Total	Max. Current. (A) 400 V	11,6
Specific rate	1,03	Motor protection	IP55
Pressure (Pa)	2903	Motor efficiency	IE3
Electric power (kW)	10,838	Limit air temperatures	-20 °C → +120 °C
Speed variator	VSD not necessary	Approx. weight. (kg)	252
		Cumplimiento ErP 2015	ErP 2015
• Established data in max. Efficiency point.		• Data may change. Please check motor cover	

PARTS

- 1 FAN
- 2 TRANSITION
- 3 FLEXIBLE CONNECTION
- 4 FOUNDATION TUBE (NOT SUPPLIED BY SYMAGA)

